

Zip FlushMaster[®] Surface mounted sensor

Water Saver Urinal Flushing System
Keeps Urinals Clean & Reduces Water Wastage

WS002



40090 Zip FlushMaster Surface Mounted Sensor / Solenoid WS002



Table of Contents

Key Features	3
Read These Warnings First	3
Check Your Package	3
Installation Procedure	3
Set Up Water Discharge	4
Install Sensor	6
Connect Latching Valve Cable	7
Connect Optional Power Pack	8
Set Flush Timing	8
Completing Installation	9
Maintenance Instructions	10
Problem Solving	11
Contact Information	12

Accessories

You may need these accessories (Check page 3 for package contents).



- 99021 Zip FlushMaster Cistern Autosyphon 1.00 inch BSP/ 25 mm
- 99022 Zip FlushMaster Cistern Autosyphon 1.25 inch BSP/ 32 mm
- 99023 Zip FlushMaster Cistern Autosyphon 1.50 inch BSP/ 38 mm



- 99024 Zip FlushMaster Direct Injection Airbreak 1.00 inch BSP / 25 mm
- 99025 Zip FlushMaster Direct Injection Airbreak 1.25 inch BSP/ 32 mm
- 99026 Zip FlushMaster Direct Injection Airbreak 1.50 inch BSP/ 38 mm

99031 Zip FlushMaster Power Pack for WS002



81841 - Restrictaflow

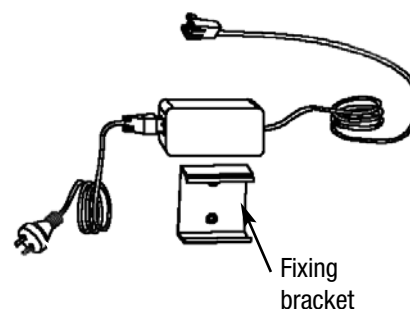

Key Features

The world's most effective urinal flushing system.
Choice of surface mounted or ceiling recessed sensors.
Battery operated for simple, inexpensive installation.
Optional power pack for connection to 220-240 volt AC power.
Operating pressure 350 - 700kPa (see notes P4)
Variable flush cycle to meet your needs precisely.

Read These Warnings First



Read all instructions before attempting to install this system.
Never attempt to install this system without reading all instructions.
Designed for indoor use only do not expose to elements of nature.
All plumbing connections must be made in accordance with AS/NZS3500 and installation with AS/NZS3500.2

Check Your Package

Zip FlushMaster package includes.



Product Code 40090
Zip FlushMaster WS002
Surface mounted sensor with
latching valve, 6V battery and
Brass fittings with Restrictaflow



Product code 90281
Latching valve and brass fittings with
Restrictaflow.



Installation Procedure

1. Set up water discharge
2. Install sensor
3. Connect latching valve cable
4. Set flush timing

Set Up Water Discharge

Typical Installation with Cistern

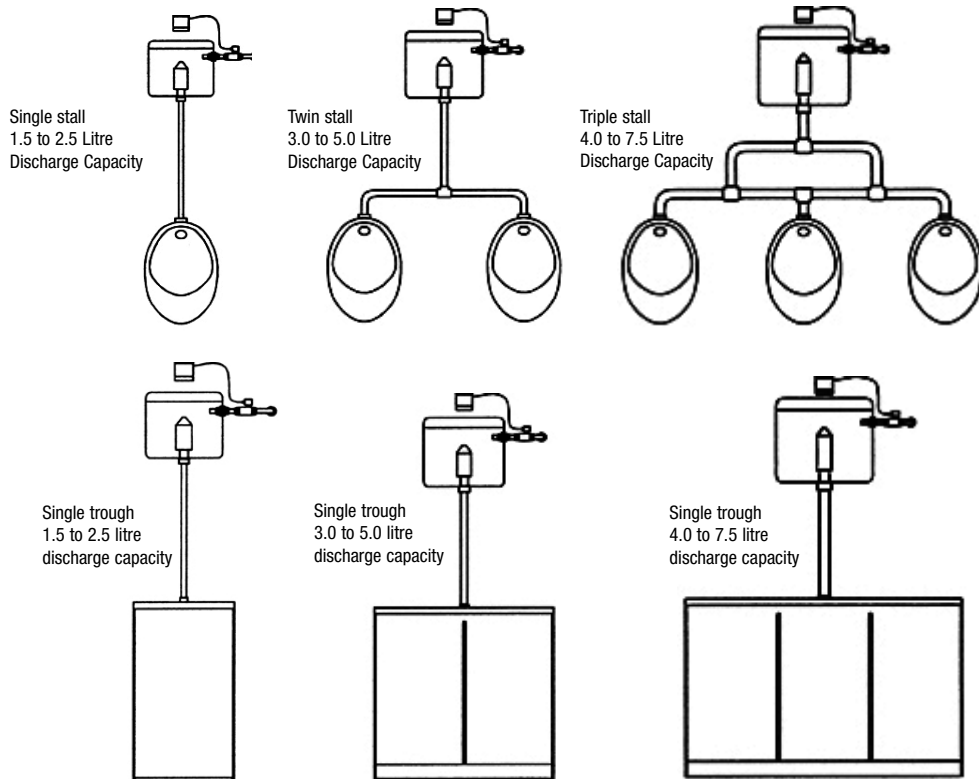

Typical Installation with Direct Injection

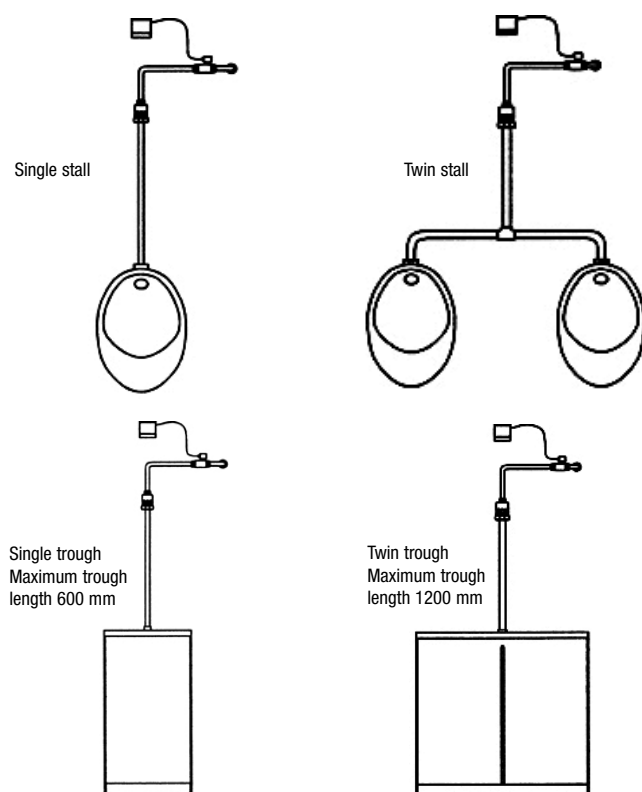

Restrictaflow Installation Notes:

- The Restrictaflow must be fitted between the isolating valve and the latching valve (see page 5).
- The Restrictaflow is designed to save water and to reduce the flow, particularly when used on single stall installations.
- The Restrictaflow may be drilled out (in 0.5mm increments) or removed, when servicing multiple stalls and a higher flow is required, or when there is insufficient water pressure.
- The Restrictaflow is normally required with operating pressures greater than 700kPa.
- An Isolating valve must be supplied and installed in accordance with AS/NZS3500

Set Up Water Discharge Continued

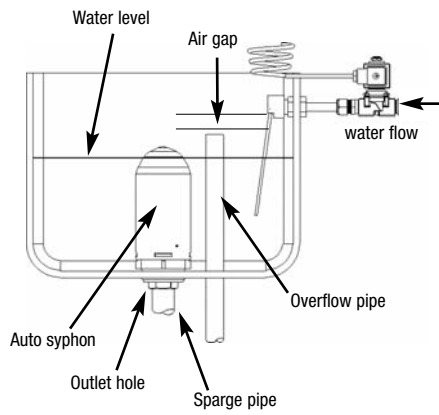

Autosyphon Installation

- More than one cistern can be fed from a single latching valve, but for accurate balancing, do not connect together more than two cisterns.
- The balance of water can be achieved by keeping the supply pipe length to each cistern as equal in length as possible.
- If this is not practical fit a flow restrictor of equal rating at the entry to each cistern.
- Remove the existing filling mechanism from the cistern, including the float and aspirin washer, to permit unrestricted inlet of the water. The flow of water into the cistern is controlled by the latching valve.
- Remove the existing manual flushing mechanism from the cistern, and fit the syphon to the outlet hole as shown in the diagram. Connect the sparge pipe to the protruding thread from the syphon.

Note: To adjust the auto syphon height within the cistern, add a second locking nut to the inside of the cistern and wind second nut up or down.

- Adjust the height of the syphon so that the flush triggering level remains below the level of the cistern overflow pipe.
- An air gap must always remain between the cistern water level and the inlet water pipe level, to prevent backflow.

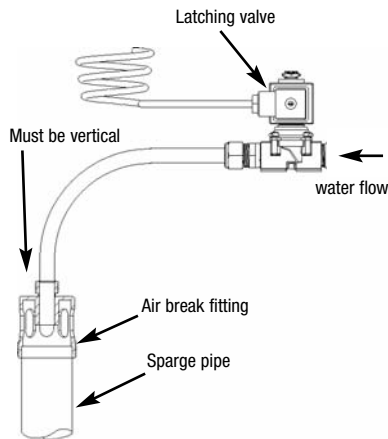

Airbreak Installation

- The air break must be fitted in a vertical position. Fitting in a position other than vertical will result in leakage.
- Fit the air break to the top of the urinal sparge pipe (in place of a cistern), as shown in the diagram.
- Do not use sealing tape in the joints. Both the air break and the latching valve use compression connections fittings. Sealing tape is not required.
- Supply and install a half-inch pipe from the top of the air break, to the outlet side of the latching valve.
- Securely fix the piping to the wall as per AS/NZS3500 to prevent possible tampering and vandalism.
- Adjust the timing of the flush to ensure an adequate flush, by setting the flush cycle switches on the sensor (see page 9).

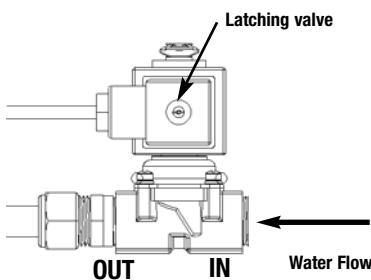

Restrictor installation:

Fit the Restrictaflow between the tap and the latching valve (see below)

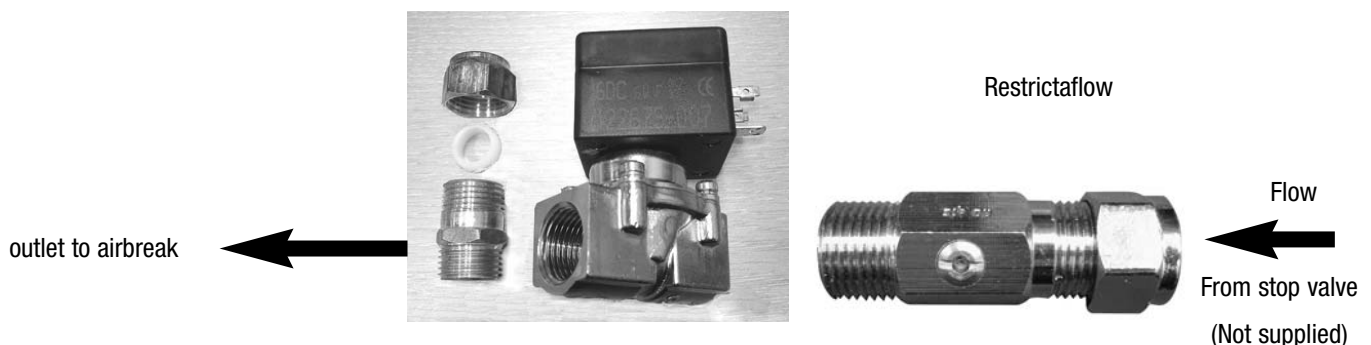

Install Sensor

Typical Installation with Surface Mounted Sensor (Model WS002)

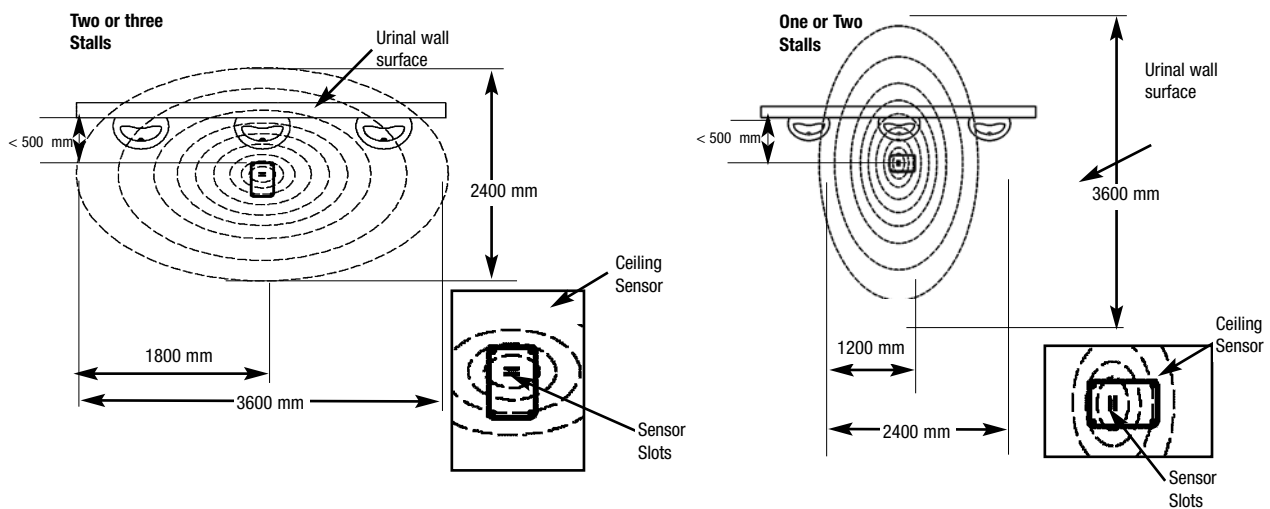

Sensor coverage from a 2700 mm ceiling is approximately 2400 x 3600 mm.

For a single stall urinal, position the sensor above the centre of the stall. Position the sensor slots at right angles to the urinal wall.

For a double stall urinal, position the sensor midway between the stalls. Position the sensor slots at right angles to the urinal wall.

For a triple stall urinal, position the sensor above the centre of all three stalls. Position the sensor slots parallel to the urinal wall.

For more than three stalls, use additional sensors.

To install a surface mounted sensor, remove top of sensor housing and fasten base of sensor housing to ceiling with screws and/or plugs (not provided).

If any of the cable connecting the sensor to the latching valve is visible, shield it with conduit.

Warning. Do not connect battery or power pack until all plumbing connections are completed. The power must be connected last as connection activates the system test mode (see page 8).

Connect Latching Valve Cable

Valve wires and valve input are colour coded

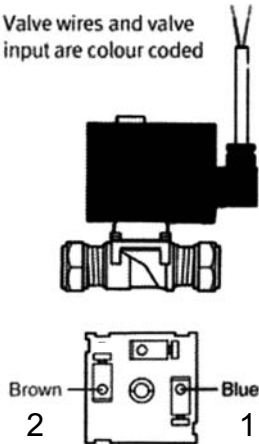

Run the latching valve cable to the sensor in conduit or within the building wall and ceiling.

Do not extend the cable as this will affect correct operation.

Locate plug on cable from the latching valve and detach it from circuit board.

The plug should be lifted directly upwards.

Fasten the latching valve cable to the plug on the circuit board by first removing the plug from the board. Lift plug directly upwards and hold plug so fixing screws are facing you.

Secure the brown cable into the right hand screw terminal and tighten.

Secure the blue cable into the left hand screw terminal and tighten.

Push the plug into the socket on the circuit board, positioned so screws face towards the centre of the board.

Finally, insert the cable from the battery pack into the circuit board inlet socket.

Once the power is connected, the system operates in test mode.



Surface Mounted Sensor

Drill a 12 mm hole in the side of the box, fit cable gland and thread cable through the cable gland into the sensor as shown.

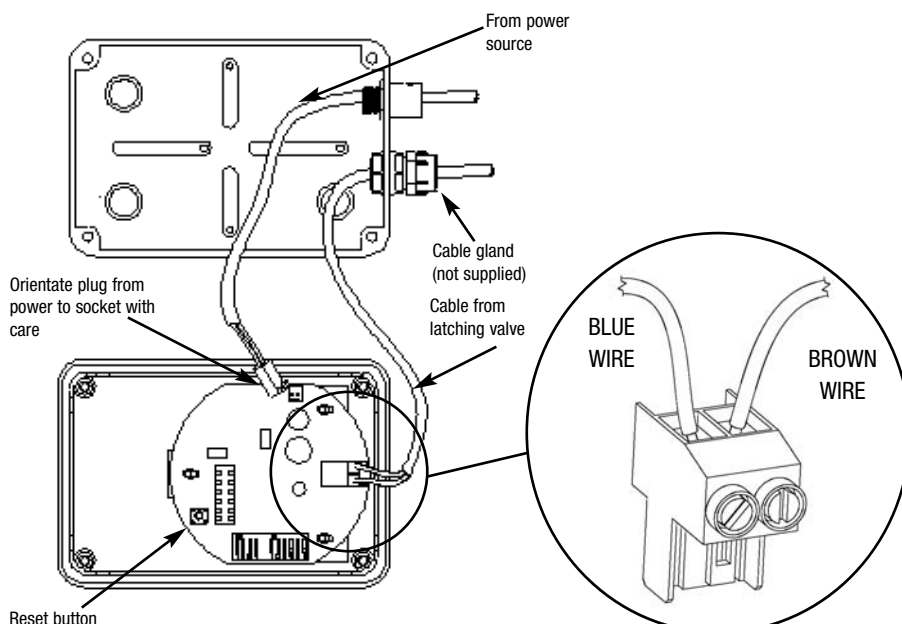

Connect Optional Power Pack

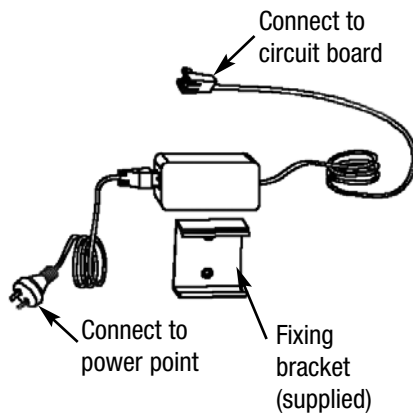

Locate battery holder and battery supplied with the system.
 If connected, remove the battery cable plug from the circuit board.
 Connect power pack to 220-240 volt 10 amp AC power point.
 Carefully align the power pack outlet cable plug to circuit board inlet socket.
 Firmly insert the cable plug from the power pack into the inlet socket.

Set Flush Timing



Wait time switches

Wait Period Delay Timer	
Switch	Minutes
1	1 min
2	2 min
3	4 min
4	8 min

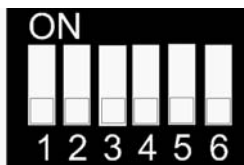

Flushing or filling time switches

ON Period Duration Timer	
Switch	Minutes
1	15 sec
2	30 sec
3	1 min
4	2 min
5	4 min
6	8 min

WS002

Test Mode

Test mode is set at approximately 45 seconds delay, 5 seconds flush.
 Check period of delay and period of flush.
 Reset timing if needed by following instructions below.

Wait Period

Switches turned 'on' add together to create total period.
 The wait period can therefore range from 45 seconds (all switches 'off'), to 15 minutes (all switches 'on', 1+2+4+8) or any other combination between.
 Setting a short wait period will reduce the life of the battery.

Flushing Period

The 'on or flushing' duration time period can be set with six switches ranging from 15 seconds to 8 minutes. The total time can therefore range from 5 seconds (all switches OFF), to 15.75 minutes (all switches ON).

Note: If the installation contains a cistern, set the 'on' period to permit the cistern to fill, activate the syphon and flush. The fill cycle should over-run the flush by a few seconds if possible to allow for pressure fluctuation.

If the installation has no cistern, a direct injection type air break must be used. Set the 'on or flushing' time to allow an adequate flush of the urinal whilst observing the flushing volume requirements of AS3500.1.

Completing Installation

On completion, fit the sensor lid to the mounting box by pushing it on tight. Fit sensor to the ceiling and wipe clean the outer surfaces. In the case of a surface mount sensor, ensure the body is securely fixed to the ceiling surface, then fit the cover by tightening the 4 fixing screws.

End of life disposal.

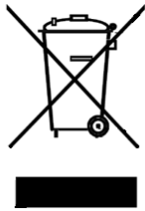

The use of this crossed out wheeled bin logo indicates that this product needs to be disposed of separately to any other household waste.

Within each of the European Union member countries, provisions have been made for the collection and recycling of unwanted electrical and electronic equipment. Outside of the EU it will be necessary to dispose of this product at your local community waste collection or recycling centre.

In order to help preserve our environment we ask that you dispose of this product correctly. Please contact your local city council for collection centre details

Maintenance Instructions

Cleaning

Keep the two slot openings in the face of the sensor clear of dirt.

Never clean the case with strong or abrasive cleaners.

Wipe with a soft cloth, warm water and dish washing liquid.

Never hose or spray any part of the flushing system.

Where the Zip FlushMaster is powered by a long life lithium battery a life of up to three years can be anticipated depending on frequency of activation.

However to avoid the inconvenience associated with any malfunction of the flushing system, it is recommended that both the battery and the latching valve diaphragm be replaced annually.

Where the optional power pack is fitted, the power must be turned off at the power point before any form of maintenance is attempted.



Battery Replacement

Remove protective cover from sensor housing, locate battery holder.

Remove cover from battery holder and remove existing battery.

Replace existing battery with lithium cell type CRP2 / 223A only. (Zip product code 90098).

Replace cover on battery holder and replace cover on sensor housing.

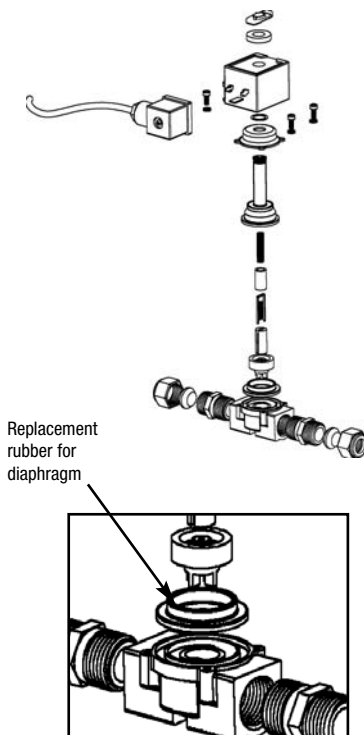

Valve Diaphragm Replacement

Isolate water supply.

Remove fixing clip on top of latching valve coil by levering up clip with screw driver and clicking back until clip releases from shaft.

Lift coil, spring clip and spacer from latching valve shaft.

Carefully undo the 4 screws retaining the valve housing. When the last screw is about to be released, grip the valve body and top section as it is spring loaded.

Carefully separate the top section containing the spring and plunger from the lower body. The diaphragm should now be visible. Lift it out of position.

Remove the centre plastic piece from the rubber diaphragm. Fit the new diaphragm to the plastic centre. Replace it in the same orientation.

Re-assemble in the reverse of above. Note the position of all parts in the diaphragm for correct assembly. To order quote Zip part number 90279 diaphragm Kit.

Problem Solving

Symptoms	Possible Causes	Suggested Action
Cistern Does not fill or direct inject does not flush.	Water supply turned off. Latching valve flow regulator full on. Latching valve installed backwards. Latching valve cable damaged or latching cable unplugged. Latching valve faulty. Sensor not activating.	Check water supply, turn on tap. Back off regulator screw. Reinstall latching valve correctly. Check cable and replug into sensor circuit board. Replace latching valve. Check sensor as below.
Cistern under fills, or direct inject flushes too long.	Sensor duration time set incorrectly. Latching valve flow regulator on.	Reset sensor timer switches.
Cistern over fills, or direct inject flushes for only 5 seconds at a time.	Sensor duration time set incorrectly. Latching valve flow regulator off.	Reset sensor timer switches.
Cistern fills or direct inject flushes for only 5 seconds at a time.	Sensor timers set to test mode.	Reset sensor timer switches.
Cistern fills or direct inject flushes for only 35 seconds at a time.	Sensor timers set to test mode and latching valve cable wires crossed.	Reset sensor timer switches and uncross latching valve wire connection.
Cistern fills or direct inject flushes continually except for time set as duration 'on' period.	Sensor cable wires crossed.	Uncross latching wire connection.
Cistern continues to fill during and after having just flushed.	Sensor duration time set incorrectly. Sensor timing out of sync with fill.	Reset sensor timer switches. Empty cistern, then restart timing.
Flushing will not stop.	False activation. Sensor not activating.	Check for sensor vibration. Check sensor as below.
Sensor not activating.	Battery flat. Power turned off. Sensor fuse blown. Lens slot blocked. Not detecting users. Faulty sensor.	Replace battery. Check Powerpack, turn on power. Replace fuse on circuit board. Clean lens slots. Reposition sensor appropriately. Replace sensor.

Warranty Information

Registering Your Purchase

Registering your Zip installation on the Zip website may help to establish date of installation should it become necessary to service the appliance under terms of the Zip warranty. To register your installation go to www.zipheaters.com and look under the heading "Warranty".

As Zip policy is one of continuous product improvement, changes to specifications may be made without prior notice. Images in this booklet have been modified and may not be true representations of the finished goods

Head Office

Zip Heaters (Aust) Pty. Ltd.
ABN 46 000 578 727
67 Allingham Street
Condell Park NSW 2200
Postal: Locked Bag 80
Bankstown 1885 Australia

Website: www.zipheaters.com
Facsimile: (02) 9796 3858
Telephone: (02) 9796 3100
Free Call: 1 800 638 633

